

Planar® T* f/2.8 – 80 mm

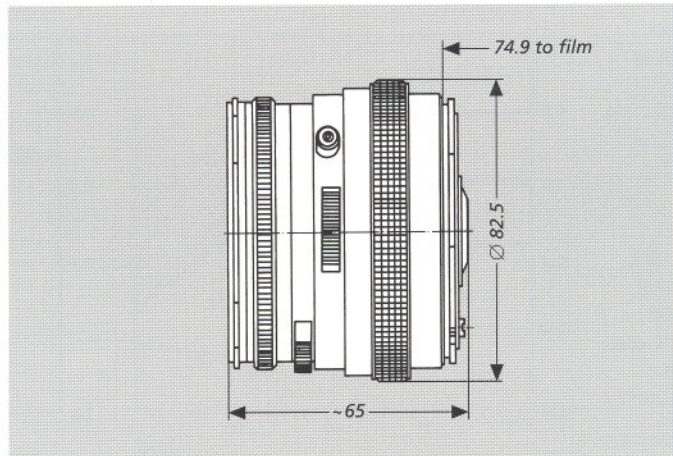

H A S S E L B L A D

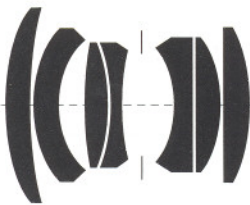

At full aperture, this Planar® T* lens features extremely uniform edge-to-edge sharpness due to the excellent correction of all aberrations associated with this lens type. As indicated by its name, the anastigmatic flatness of the image field is outstanding.

In addition to the 100 mm Planar® T* f/3.5 lens, the 80 mm Planar® T* f/2.8 lens – whose focal length is about as long as the diagonal of the 6 x 6 cm format – is part of the standard outfit for the range of Hasselblad SLR cameras. The lens is suitable for almost any application in general photography.

Cat. No. of lens:	10 21 65	Close-limit field size:	517 x 517 mm
Number of elements:	7	Entrance pupil:	
Number of groups:	5	Position:	26.6 mm behind the first lens vertex
Max. aperture:	f/2.8	Diameter:	28.8 mm
Focal length:	81.2 mm	Exit pupil:	
Negative size:	56.5 x 56.5 mm	Position:	25.7 mm in front of the last lens vertex
Angular field 2w:	diagonal 52°, side 38°	Diameter:	34.5 mm
Spectral range:	visible spectrum	Position of principal planes:	
Aperture scale:	2.8 – 4 – 5.6 – 8 – 11 – 16 – 22	H:	39.0 mm behind the first lens vertex
Mount:	Prontor CF shutter	H':	10.8 mm in front of the last lens vertex
Filter connection:	bayonet for Hasselblad series 60	Back focal distance:	69.9 mm
Weight:	approx. 510 g	Distance between first and last lens vertex:	46.4 mm
Focusing range:	∞ to 0.9 m		
Reproduction ratio:	0 to 1:9		

Planar
100 Years



Performance data: Planar® T* f/2.8 – 80 mm No. 102165

1. MTF Diagrams

The image height u – calculated from the image center – is entered in mm on the horizontal axis of the graph. The modulation transfer T (MTF = Modulation Transfer Factor) is entered on the vertical axis. Parameters of the graph are the spatial frequencies R in cycles (line pairs) per mm given at the top of this page.

The lowest spatial frequency corresponds to the upper pair of curves, the highest spatial frequency to the lower pair. Above each graph, the f-number k is given for which the measurement was made. "White" light means that the measurement was made with a subject illumination having the approximate spectral distribution of daylight.

Unless otherwise indicated, the performance data refer to large object distances, for which normal photographic lenses are primarily used.

2. Relative illuminance

In this diagram the horizontal axis gives the image height u in mm and the vertical axis the relative illuminance E , both for full aperture and a moderately stopped-down lens. The values for E are determined taking into account vignetting and natural light decrease.

Modulation transfer T as a function of image height u . Slit orientation: tangential --- sagittal —
White light. Spatial frequencies $R = 10, 20$ and 40 cycles/mm

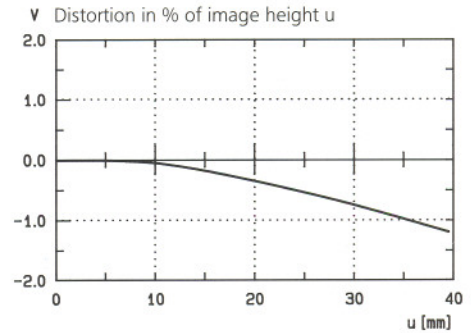
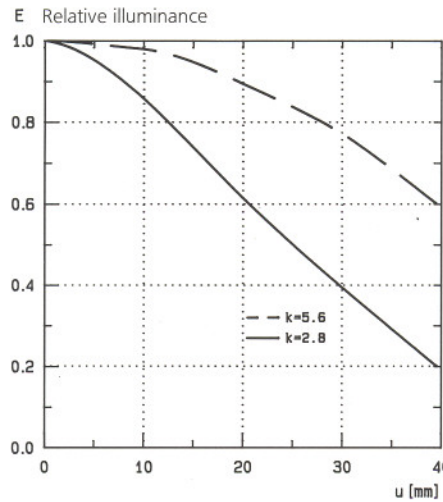
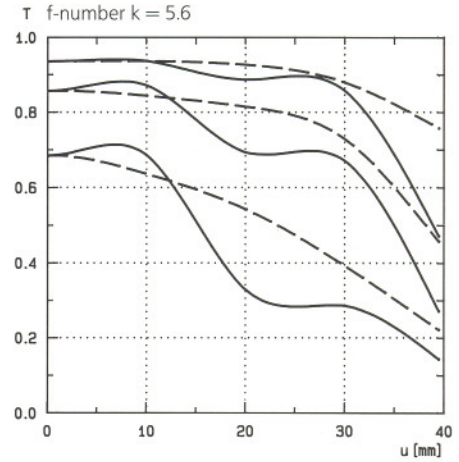
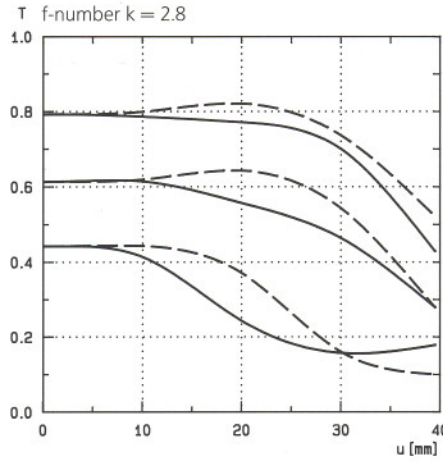

3. Distortion

Here again the image height u is entered on the horizontal axis in mm. The vertical axis gives the distortion V in % of the relevant image height. A positive value for V means that the actual image point is further from the image center than with perfectly distortion-free imaging (pincushion distortion); a negative V indicates barrel distortion.



Carl Zeiss
Photoobjektive
D-73446 Oberkochen
Tel.: (0 73 64) 20-61 75
Fax: (0 73 64) 20 40 45

For advice, please contact