



High performance, full format cinema zoom lenses

ZEISS Cinema Zoom lenses



Capturing cinema.

ZEISS Cinema Zoom Lenses



// INSPIRATION
MADE BY ZEISS



watch mount change video at: <https://youtu.be/NJTewQ-V3rM>

High-performance cinema zoom lenses that make the most of the moment

The ZEISS Cinema Zoom lenses deliver great flexibility thanks to interchangeable mounts, allowing them to be used with a wide range of cameras from multiple manufacturers. There is a comprehensive choice of cinema zooms with consistent aperture, good sharpness, high contrast, minimal distortion and a look that matches the highest quality cinema primes including ZEISS/ARRI lenses. Affordable, flexible and offering the best performance, the ZEISS Cinema Zoom lenses are an invaluable addition to any film set.

Unparalleled versatility

The ZEISS Cinema Zoom lenses are the world's first zoom lenses designed for all types of high-end digital movie cameras. The interchangeable mount guarantees high flexibility for present and future use in any situation and for a wide range of camera platforms.

Made in Germany



Absolute flexibility

The ZEISS Cinema Zoom lenses are as versatile as they are powerful and incorporate features never seen before on lenses of this kind. They are handy, compact, ready for 8K and beyond and even offer full-frame coverage. With their zoom length of 15–30, 28–80 and 70–200mm, they give you a wide range of creative options.

Truly stellar performance

The size and weight of the ZEISS Cinema Zoom lenses make the lenses perfect. All three zoom lenses are color-matched not just to each other, but they also fit perfectly to all ZEISS cinema prime lenses such as the ZEISS/ARRI Master Prime lenses and ZEISS/ARRI Ultra Prime lenses. The ZEISS Cinema Zoom lenses are ideal for top-quality movies, feature film productions and documentaries.

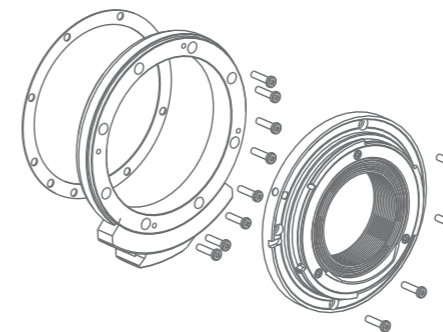

- Allows a mix of professional cine cameras, for maximum flexibility on set
- No loss of image quality due to adapter solutions
- Five different mounts available (PL, EF, F, MFT and E mount)
- User Interchangeable Lens Mounts

User Interchangeable Lens Mounts



EF-mount



MFT-mount



PL-mount



Nikon F-mount



Sony E-mount



watch the cinema zoom family in action at: <https://vimeo.com/169548698>



Future-proof performance with full-frame coverage

ZEISS Cinema Zoom lenses feature exquisite optics in a robust, durable package – two characteristics that will surely remain desirable for decades to come. And thanks to their interchangeable mounts, Cinema Zoom lenses offer the possibility to upgrade to any number of existing or future cine cameras while using the same set of lenses. Additionally, they all cover a full-frame image format without vignetting.

Unrivalled image quality – ready for high resolution cameras!

ZEISS Cinema Zoom lenses are precision-engineered within the tightest possible tolerances. This guarantees you excellent image quality with low distortion, high resolution and excellent color rendition for sharp, punchy pictures.



- Full-frame coverage (36 x 24 mm) for focal lengths of 15 to 200 mm
- Homogeneous aperture of T2.9
- Interchangeable mount
- No visible focus shift while change of focal length
- Robust cine-style housing
- No visible breathing
- Calibrated focus scales
- Nearly 300 degree focus rotation
- Round iris for organic look
- No visible ramping



Sweet spot effect with Super 35 sensors



- Excellent color correction
- Great flare suppression through T*® anti-reflex coating and internal light traps
- Low distortion
- Round out-of-focus highlights
- Color-matched

High resolution and contrast; ready for 8K and beyond

	Mount	Aperture	Focal Length (Wide/Long)	Close Focus ¹	Length ²	Front diameter	Weight	Horizontal Angle of View					
								Full-Frame ³	APS-H ⁴	Super 35 ⁵	Normal 35 ⁶	APS-C ⁷	MFT ⁸
CZ.2 15 – 30 mm T2.9	PL, EF, F, E, MFT	T 2.9 to T 22	15 mm/ 30 mm	0,55 m 1'1"	198 mm 9.92"	114 mm 4.49"	2.6 kg 5.7 lbs	Wide 100°	90°	79°	72°	73°	59°
								Long 62°	54°	46°	41°	42°	33°
CZ.2 28 – 80 mm T2.9	PL, EF, F, E, MFT	T 2.9 to T 22	28 mm/ 80 mm	0,83 m 2'8"	196 mm 7.72"	95 mm 3.7"	2.5 kg 5.5 lbs	Wide 66°	57°	48°	43°	43°	34°
								Long 25°	21°	18°	16°	16°	12°
CZ.2 70 – 200 mm T2.9	PL, EF, F, E, MFT	T 2.9 to T 22	70 mm/ 200 mm	1,52m 5'	250 mm 9.84"	95 mm 3.7"	2.8 kg 6.2 lbs	Wide 29°	24°	20°	18°	18°	14°
								Long 10°	9°	7°	6°	6°	5°

¹ Close focus distance is measured from the image plane; ² Front to PL mount flange; ³ Horizontal angle of view for a full-frame camera (aspect ratio 1:1.5, dimensions 36 mm x 24 mm / 1.42" x 0.94"); ⁴ Horizontal angle of view for an APS-H camera (aspect ratio 1:1.81, dimensions 30.2 mm x 16.7 mm / 1.19" x 0.66"); ⁵ Horizontal angle of view for an ANSI Super 35 Silent camera (aspect ratio 1:1.33, dimensions 24.9 mm x 18.7 mm / 0.98" x 0.74"); ⁶ Horizontal angle of view for a Normal 35 Academy camera (aspect ratio 1:1.37, dimensions 22 mm x 16 mm / 0.87" x 0.63"); ⁷ Horizontal angle of view for an APS-C camera (aspect ratio 1:1.50, dimensions 22.3 mm x 14.9 mm / 0.88" x 0.59"); ⁸ Horizontal angle of view for a Micro 4/3 (MFT) camera (aspect ratio 1:1.33, dimensions 17.3 mm x 13 mm / 0.68" x 0.51");

Carl Zeiss AG
Camera Lenses
73446 Oberkochen
Germany

www.zeiss.com/cine

LENSPIRE   

Become part of the ZEISS community
www.zeiss.com/photo/social